

Throttle Position Sensor with Integrated Spring Return System



FEATURES

- High performance, compact potentiometric sensor
- Rugged construction, suitable for under-bonnet engine management and closed loop feedback applications
- Through-hole actuation capability
- Integral connector or flying lead versions
- Actuator and mounting configuration options

Spectrol Model 971 series Rotary Position Sensors are suitable for demanding environments where high life and consistent linearity performance is required. Typical applications include Electrical Industrial Vehicles, Off-Road Vehicle Steering and Transmission, Automotive Engine Management Systems and Controls.

The 971 Rotational Position Sensor can be supplied with options for electrical track length, resistance, flying leads, integral connector and actuator drive direction

ELECTRICAL SPECIFICATIONS	
PARAMETER	
Total Resistance Optional	5 kΩ at + 25 °C 1 kΩ to 25 kΩ
Resistance Tolerance	± 20 %
Linearity (Independent)	± 2 %
Electrical Travel	106° optional to 130° max.
Maximum Power Rating	1 W at 40 °C derated to zero at 135 °C
Output Smoothness	0.3 % max.
Temperature Coefficient	± 600 ppm/°C
Index Point (e/E)	3 % ± 2 %
Maximum Voltage	13.5 V _{DC}

MECHANICAL SPECIFICATIONS	
PARAMETER	
Rotation Optional	130° ± 5° CCW CCW or CW up to 140° max. ± 5 %
Spring Torque	120 mNm max.
Stop Strength	680 mNm min.
End Play	0.25 mm max.
Lead Wires	Nominal Ø 1.8 mm length optional
Wire Pull Strength	10 kg max. (3 wires)

ORDERING INFORMATION/DESCRIPTION		
971 MODEL	0001 OUTPUT TYPE 0001: Amp connector 0002: Flying leads	B0100 PACKAGING Box of 100 pieces

SAP PART NUMBERING GUIDELINES		
971 MODEL	0001 STYLE	B30 PACKAGING



**Throttle Position Sensor with
Integrated Spring Return System**

DIMENSIONS in inches (millimeters)

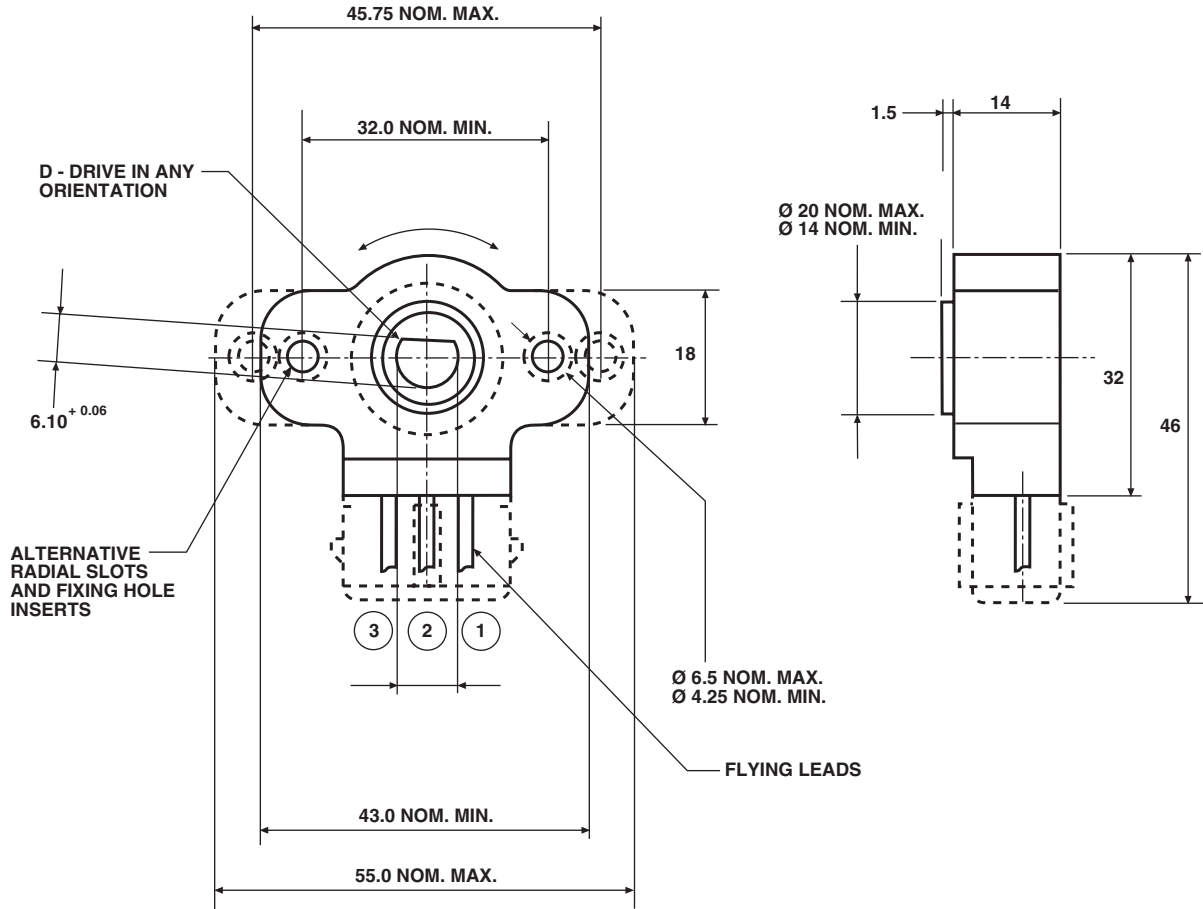

ENVIRONMENTAL SPECIFICATIONS	
Rotational Life	5 x 10 ⁶ full cycles
Dither	10 x 10 ⁶ (2° rotation)
Vibration	15 g, 50 to 1000 Hz
Shock	50 g
Temperature Range: Standard Operating Optional Operating	- 40 °C to + 85 °C - 40 °C to + 130 °C
Materials: Housing	Polyester PBT
Leads: Standard PVC High Temperature PVC	+ 85 °C + 130 °C

OPTIONAL INTEGRAL CONNECTOR	
AMP style Junior Timer Mates: Housing Terminals	1 - 8275782 - 1 (unsealed) 927845 - 2
Housing Terminals Wire Seals	282191 - 1 (sealed) 929939 - 3 828904 - 1



Disclaimer

All product specifications and data are subject to change without notice.

Vishay Intertechnology, Inc., its affiliates, agents, and employees, and all persons acting on its or their behalf (collectively, "Vishay"), disclaim any and all liability for any errors, inaccuracies or incompleteness contained herein or in any other disclosure relating to any product.

Vishay disclaims any and all liability arising out of the use or application of any product described herein or of any information provided herein to the maximum extent permitted by law. The product specifications do not expand or otherwise modify Vishay's terms and conditions of purchase, including but not limited to the warranty expressed therein, which apply to these products.

No license, express or implied, by estoppel or otherwise, to any intellectual property rights is granted by this document or by any conduct of Vishay.

The products shown herein are not designed for use in medical, life-saving, or life-sustaining applications unless otherwise expressly indicated. Customers using or selling Vishay products not expressly indicated for use in such applications do so entirely at their own risk and agree to fully indemnify Vishay for any damages arising or resulting from such use or sale. Please contact authorized Vishay personnel to obtain written terms and conditions regarding products designed for such applications.

Product names and markings noted herein may be trademarks of their respective owners.

Definition of Sealing Protection Levels

Vishay



PROTECTION LEVELS	
FIRST DIGIT	SECOND DIGIT
PROTECTION AGAINST SOLID SUBSTANCES	PROTECTION AGAINST LIQUIDS
IP Tests	IP Tests
0 Without Protection	0 Without Protection
1 Protected against solid substances (size > 50mm)	1 Protected against water drops (condensation)
2 Protected against solid substances (size > 12mm)	2 Protected against water drops from up to 15 feet
3 Protected against solid substances (size > 2.5 mm)	3 Protected against water drops up to 60 feet
4 Protected against solid substances (size > 1 mm)	4 Protected against water drops above 60 feet
5 Protected against dust (> 0.1mm < 1mm)	5 Protected against splashes of water in all directions
6 Fully protected against dust	6 Protected against projections of water in all directions
	7 Protected against action of immersion < 15 cm and water jet pressure all directions
	8 Protected against long time action of immersion < 1 meter and water jet pressure in all directions

NOTE: To symbolize the protection levels, we use ip letters followed by 2 digits.

Conductive Plastic Technology

The polymer film track has a conductive plastic paste laid upon it. This paste includes an inert filler of carbon black which constitutes the basis of Vishay SFERNICE's technology for manufacturing precision potentiometers.

The resistive track obtained can be used:

- inside a cylindrical housing for making a rotational potentiometer
- on a flat support when manufacturing a linear motion transducer.

This method of producing the plastic film creates a resistive track which is exceptionally uniform in its resistivity and which allows excellent results regarding linearity.

1 - FUNCTION AND PRINCIPLE

The function of a motion transducer is to convert a mechanical displacement, either rotational or linear, into an electrical signal.

In order to achieve this, the resistive track is placed on the fixed part of the potentiometer and the mechanical displacement to be measured is connected to the wiper assembly which moves on the resistive track.

The track of the potentiometer is connected to a stabilised DC voltage which allows a small current flow (μ Amperes). The voltage, when measured between the wiper and the input turret, is directly proportional to the position of the wiper on the track.

The use of the potentiometer as a voltage divider, minimises the necessity for accuracy of the total resistance of the track because the changes in resistance, due to the variations of temperature, do not affect the measured result.

2 - COMMON APPLICATIONS

Conductive plastic potentiometers are used in all kinds of fields e.g.: military, aerospace, automotive, medical, measurement, robotics, nuclear and of course general industrial.

In particular they are suitable for guided missiles, flight control equipment, wheel balancing and wheel alignment machinery for vehicles, XY chart recorder, physiotherapy apparatus, professional joystick and servo control of actuators on moulding machinery.

3 - HOW TO CHOOSE A MOTION TRANSDUCER

Important parameters include :

- precision of the linearity required
- expected lifespan of the product
- repeatability and resolution
- price.

For particular applications, other features may also be critical when choosing the technology :

- low torque requirement
- device exposed to vibration or shock
- high speed application.

Conductive Plastic Film Motion Transducers are excellent value for money in relation to the performance offered and the electrical and mechanical characteristics of each product are detailed in this catalog.

4 - TECHNICAL PARAMETERS - DEFINITIONS

4.1 - TOTAL APPLIED VOLTAGE "E"

The total voltage applied between the designated input terminals.

E = Total applied voltage (peak to peak applied voltage).

4.2 - OUTPUT VOLTAGE "e"

The voltage between the wiper and the designated reference point. Unless otherwise specified, the designated reference point is the CCW terminal.

4.3 - OUTPUT RATIO $\frac{e}{E}$

The ratio of the output voltage to the designated input reference voltage. Unless otherwise specified the reference voltage is the total applied voltage.

4.4 - CONFORMITY

The fidelity of the relationship between the actual function characteristic and the theoretical function characteristic.

Mathematically: $\frac{e}{E} = f(q) +/- C$

4.5 - LINEARITY

A specific type of conformity where theoretical function characteristic is a straight line.

Mathematically: $\frac{e}{E} = f(q) +/- C = A(q) + B +/- C$

Where A is a given slope; B is a given intercept at $q = 0$.

4.6 - INDEPENDENT LINEARITY

The maximum deviation of the actual function characteristic from a straight reference line with its slope and position chosen to minimize the maximum deviations. It is expressed as a percentage of the total applied voltage and is measured over the specified theoretical electrical travel.

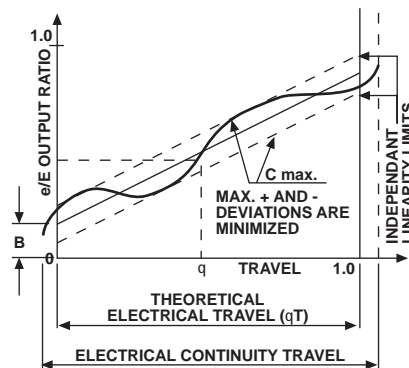

4.7 - ABSOLUTE LINEARITY

This linearity is harder to achieve than the one above because it is the maximum deviation of the actual function characteristic from a fully defined straight reference line. It is expressed as a percentage of the total applied voltage and measured over the theoretical electrical travel. An index point on the actual output is required.

The straight reference line may be fully defined by specifying the low and high theoretical end output ratios separated by the theoretical electrical travel. Unless otherwise specified, these end output ratios are 0.0 and 1.0, respectively.

Mathematically:
$$\frac{e}{E} = A(q / q T) + B \pm C$$

Where: A is a given slope; B is a given intercept at q = 0.

Unless otherwise specified A = 1; B = 0.

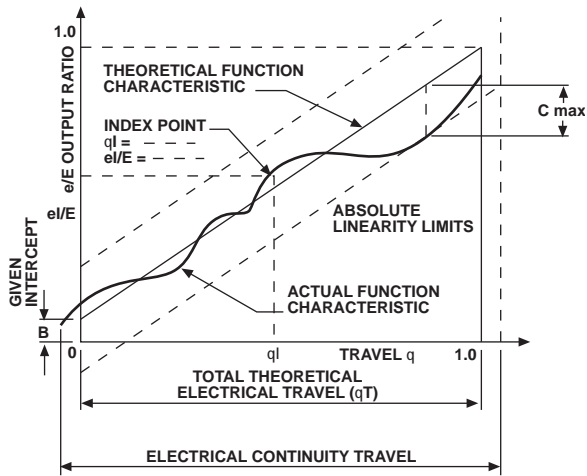

4.8 - LIFE

The number of shaft revolutions or travels obtainable under specific operating conditions and within specified allowable degradations of specific characteristics.

4.9 - RESOLUTION

A measure of the sensitivity to which the output ratio of the potentiometer may be set.

4.10 - REPEATABILITY

It is the maximum difference found on the output ratio for a same mechanical position all along the theoretical electrical stroke after several travels. It is expressed as a percentage of the total applied voltage.

4.11 - TRAVELS

4.11.1 - Theoretical electrical travel: TET

The specified shaft travel over which the theoretical function characteristic and its associated conformity limits are respected.

4.11.2 - Actual electrical travel : AET

The total travel of the shaft between the two points at which the first and the last measurable change in output ratio occur.

4.11.3 - Mechanical travel : MT

The total travel of the shaft between integral stops. In potentiometers without stops, the mechanical travel is continuous (rotationals only!).

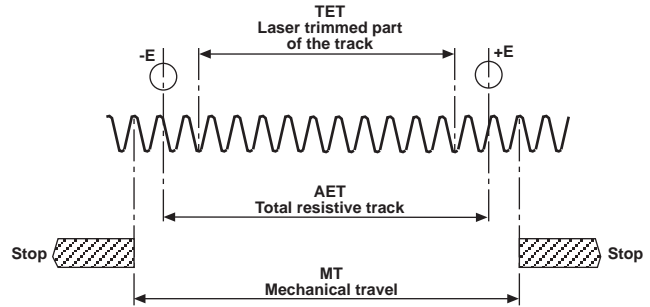

4.12 - GRADIENT

The rate of change of output ratio relative to shaft travel.

$$G = \frac{de/E}{dq} \quad (\text{mV/V}^\circ) \quad \text{rotational} \quad G = \frac{de/E}{d} \quad (\text{mV/V/mm}) \quad \text{linear}$$

4.13 - INDEX POINT

A point of reference fixing the relationship between a specified shaft position and the output ratio. It is used to establish a shaft position reference.

4.14 - OUTPUT SMOOTHNESS

Output smoothness is a measurement of any spurious variation in the electrical output not present in the input. It is expressed as a percentage of the total applied voltage and measured for specified travel increments over the theoretical electrical travel. Output smoothness includes effects of contact resistance variations, resolution, and other micro-nonlinearities in the output.

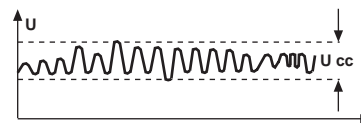

U_{cc} : maximum variations peak to peak.

$$RTS = \frac{U_{cc}}{E} \times 100 = \dots \%$$

4.15 - END VOLTAGE

The voltage between the wiper terminal and an end terminal when the shaft is positioned at the corresponding end of electrical continuity travel. End voltage is expressed as a percentage of the total applied voltage.

4.16 - VOLTAGE TAP

An electrical connection fixed to the resistance element which introduces no significant distortion in the output characteristic. A voltage tap usually has significant tap resistance and may not be capable of carrying rated element current. A voltage tap involves a fourth turret which delivers a fixed voltage. This voltage only depends on the position of the tap on the track and of the total applied voltage. It is usually located in the middle of the TET.

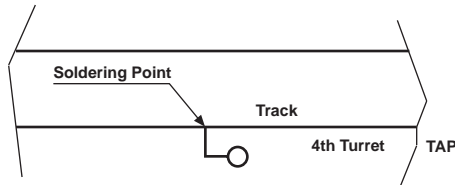

4.17 - CURRENT TAP

An electrical connection fixed to the resistance element which is capable of carrying rated element current and may distort the output characteristic.

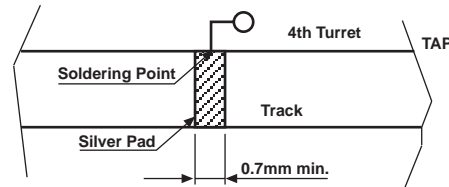

4.18 - STARTING TORQUE

The moment in the clockwise and counterclockwise directions required to initiate shaft rotation anywhere in the total mechanical travel.

4.19 - MOMENT OF INERTIA

The mass moment of inertia of the rotating elements of the potentiometer about their rotational axis



VISHAY INTERTECHNOLOGY, INC.



ROTATIONAL TRANSDUCERS

Industrial Conductive Plastic and Custom, Single-Turn Models



Rotational Transducers

Industrial Conductive Plastic and Custom, Single-Turn Models

FEATURES

- Long life: from 2 million to 30 million cycles
- Custom designs available:
 - special electrical angles
 - various shaft types
 - outputs by flying leads and connectors

- Cost-effective component solutions
- Different models (sizes and shapes)

APPLICATIONS

- Servo control of industrial valves, various functions for fork-lift trucks and tractors, joysticks, wheel balancing equipment for cars

Model	Electrical Travel (°)	High Accuracy (Linearity)	Repeat-ability	Ohmic Values	Resistance Tolerance at 20 °C	Starting Torque N.cm	Operating Life (Millions of Cycles)	Temperature Range (°C)	External Diameter (mm)	Options
157-1 *1	340° ±4°	< ±2 % to < ±0.25 %	–	1 KΩ to 100 KΩ	±20 %	0.20 max.	10	-55 °C to +125 °C	22.2	Special electrical angles
357 *1	340° ±3°	< ±2 % to < ±1 %	–	1 KΩ to 50 KΩ	±20 %	0.4 max.	5	-55 °C to +125 °C	22.2	Special electrical angles
78 PB/RB *1	340° ±5°	< ±2 % to < ±0.35 %	–	1 KΩ to 50 KΩ	±20 %	0.5 max.	5	-55 °C to +125 °C	22.2	Special electrical angles
78 PS/RS *2	340° ±5°	< ±2 % to < ±0.35 %	–	1 KΩ to 50 KΩ	±20 %	0.5 max.	5	-55 °C to +125 °C	22.2	Special electrical angles
157-2 *2	340° ±4°	< ±2 % to < ±0.25 %	–	1 KΩ to 100 KΩ	±20 %	0.2 max.	10	-55 °C to +125 °C	22.2	Special electrical angles
358 *2	340° ±3°	< ±2 % to < ±1 %	–	1 KΩ to 50 KΩ	±20 %	0.4 max.	5	-55 °C to +125 °C	22.2	Special electrical angles
359 *2	345° ±5°	< ±2 %	–	1 KΩ to 10 KΩ	±20 %	< 0.3	2	-55 °C to +125 °C	12.7	Special electrical angles
50 CB *1	330° ±5°	< ±1 % to < ±0.25 %	< 0.01 %	1 KΩ to 20 KΩ	±20 %	< 0.5	20	-55 °C to +125 °C	12.7	Special electrical angles
50 ES *2	330° ±5°	< ±1 % to < ±0.25 %	< 0.01 %	1 KΩ to 20 KΩ	±10 %	< 0.2	30	-55 °C to +125 °C	12.7	Special electrical angles
159-1 *1	340° ±4°	< ±0.5 % to < ±0.25 %	–	500 to 2 MΩ	±20 %	< 0.3	2	-55 °C to +150 °C	22.2	
78 CB *1	340° ±5°	< ±1 % to < ±0.25 %	< 0.01 %	1 KΩ to 20 KΩ	±20 %	< 0.5	20	-55 °C to +125 °C	22.2	Special electrical angles
78 CS *2	340° ±5°	< ±1 % to < ±0.25 %	< 0.01 %	1 KΩ to 20 KΩ	±20 %	< 0.5	20	-55 °C to +125 °C	22.2	Special electrical angles
159-2 *2	340° ±4°	< ±0.5 % to < ±0.25 %	–	500 Ω to 2 MΩ	±20 %	< 0.2	5	-55 °C to +150 °C	22.2	

*1 Bushing Mount *4 Mechanical Encoder *7 Smart Potentiometer
 *2 Servo Mounting *5 Optical Encoder
 *3 Throttle Potentiometer *6 Hall Effect



Model	Electrical Travel (°)	High Accuracy (Linearity)	Repeatability	Ohmic Values	Resistance Tolerance at 20 °C	Starting Torque N.cm	Operating Life (Millions of Cycles)	Temperature Range (°C)	External Diameter (mm)	Options
78 ES *2	340° ±5°	< ±1 % to < ±0.25 %	< 0.01 %	1 KΩ to 20 KΩ	±10 %	< 0.2	30	-55 °C to +125 °C	22.2	Special electrical angles
138 *1	345° ±4°	< ±0.5 % to < ±0.25 %	-	1 KΩ to 50 KΩ	±10 %	< 0.8	2	-55 °C to +125 °C	33.3	Stops on request
156 CB *1	350° ±3°	< ±1 % to < ±0.25 %	< 0.01 %	1 KΩ to 20 KΩ	±20 %	< 0.5	20	-55 °C to +125 °C	33.3	Special electrical angles
139 *1	345° ±4°	< ±0.5 % to < ±0.25 %	-	500 Ω to 2 MΩ	±20 %	< 0.8	2	-55 °C to +150 °C	33.3	Stops on request
156 CS *2	350° ±3°	< ±1 % to < ±0.25 %	< 0.01 %	1 KΩ to 20 KΩ	±20 %	< 0.5	20	-55 °C to +125 °C	33.3	
156 ES *2	350° ±3°	< ±1 % to < ±0.25 %	< 0.01 %	1 KΩ to 20 KΩ	±10 %	< 0.2	30	-55 °C to +125 °C	33.3	
657 *1	240° ±4°	< ±2 %	-	1 KΩ to 100 KΩ	±20 %	< 2.5	2	-40 °C to +125 °C	17.5 x 16 x 12.7	
RMF	340° ±3° or 350° ±2°	< ±1 % to < ±0.05 %	< 0.01 %	1 KΩ to 20 KΩ	±20 %	-	50	-30 °C to +85 °C	-	
601-1045 *7	360°	±1 %	N.A.	N.A.	N.A.	< 0.4	5	-40 °C to +70 °C	44 x 33 x 20	
970-1036 *3	200°	±2 %	N.A.	5 KΩ	±20 %	< 11.5	5	-40 °C to +130 °C	55 x 51 x 25	
971 *3	106° (130°)	±2 %	N.A.	5 KΩ	±20 %	< 12	5	-40 °C to +85 °C	43 x 32 x 14	
DE2 *4	360°	2 channels up to 128 pulses	N.A.	N.A.	N.A.	< 0.8	5	-20 °C to +85 °C	Cylindrical ext. Diam.33.3	
120E *5	360°	2 channels up to 128 pulses	N.A.	N.A.	N.A.	< 1.10	10	-40 °C to +65 °C	29 x 12	
RHE *6	45°/60°/80°/90°/180°	±2 %	N.A.	N.A.	N.A.	< 1.50	10	-40 °C to +85 °C	Cylindrical ext. Diam.27.8	

SEMICONDUCTORS:

Rectifiers • High-Power Diodes and Thyristors • Small-Signal Diodes • Zener and Suppressor Diodes
• FETs • RF Transistors • Optoelectronics • ICs • Modules and Assemblies

PASSIVE COMPONENTS:

Resistive Products • Magnetics • Capacitors • Strain Gage Transducers and Stress Analysis Systems



One of the World's Largest Manufacturers of Discrete Semiconductors and Passive Components

WORLDWIDE SALES CONTACTS

THE AMERICAS

UNITED STATES

VISHAY AMERICAS
ONE GREENWICH PLACE
SHELTON, CT 06484
UNITED STATES
PH: +1-402-563-6866
FAX: +1-402-563-6296

ASIA

SINGAPORE

VISHAY INTERTECHNOLOGY
ASIA PTE LTD.
25 TAMPINES STREET 92
KEPPEL BUILDING #02-00
SINGAPORE 528877
PH: +65-6788-6668
FAX: +65-6788-0988

P.R.C.

VISHAY TRADING (SHANGHAI) CO., LTD.
(SHANGHAI REPRESENTATIVE OFFICE)
ROOM D, 15F, SUN TONG INFOPORT PLAZA
55 HUAI HAI WEST ROAD
200030 SHANGHAI
P.R.C.
PH: +86-21-5258-5000
FAX: +86-21-5258-7979

JAPAN

VISHAY JAPAN CO., LTD.
MG IKENOHATA BLDG. 4F
1-2-18, IKENOHATA
TAITO-KU
TOKYO 110-0008
JAPAN
PH: +81-3-5832-6210
FAX: +81-3-5832-6260

EUROPE

GERMANY

VISHAY EUROPE SALES GMBH
GEHEIMRAT-ROSENTHAL-STR. 100
95100 SELB
GERMANY
PH: +49-9287-71-0
FAX: +49-9287-70435

FRANCE

VISHAY S.A.
199, BLVD DE LA MADELEINE
06003 NICE, CEDEX 1
FRANCE
PH: +33-4-9337-2920
FAX: +33-4-9337-2997

NETHERLANDS

VISHAY BCCOMPONENTS B.V.
HURKESTRAAT 31
P.O. BOX 8766
5652 AH EINDHOVEN
NETHERLANDS
PH: +31-40-2590-700
FAX: +31-40-2590-777

www.vishay.com